



Solid Plastic Seats Elongated

Institutional • Commercial • Extra Heavy-Duty

1500 SERIES



Available in Antimicrobial.

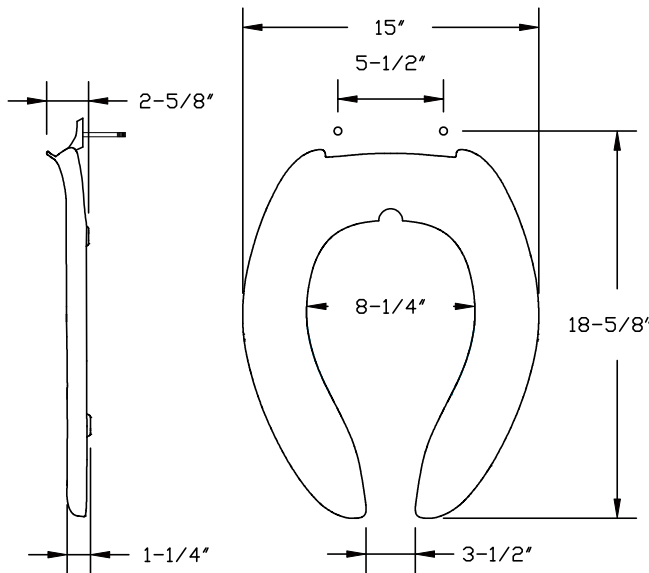

DETAILS

AMFR1500STSCSS

Antimicrobial, fire retardant, Extra heavy-duty, open front less cover for elongated bowl. Self-sustaining stainless steel check-hinge with gasket, metal flat washers, lock washers and stainless steel nuts.

Standard Features:

- Corrosion-free stainless steel hinge posts
- Check-hinge posts
- Extended back with concealed hinge
- Integrally-molded, permanent and sanitary color-keyed bumpers
- Corrosion-free hardware
- Withstands cleansers, strong chemicals
- Self-sustaining hinge available

U.S.:

Antimicrobial additive inhibits the growth of stain and odor causing bacteria on the surface.

CANADA :

Contains CESA-MB8233 as a preservative for the protection of this article.

Dimensions shown are nominal and may vary within a range of tolerance.